



## KNSP-04 Waterproof Telephone Analog

### DESCRIPTION ITEM NO.

1. Robust aluminium alloy die-cast body, Vandal & tamper-resistant hardware, easy Installation.
2. Waterproof rating IP66 dust proof.
3. Without keypad, hands-free Mode. support hotline setting. support scroll dialing.
4. Door cover: orient automatically and good self - closing, convenient for use
5. Heavy Duty handset with hearing Aid compatible (HAC) receiver, Noise canceling microphone.
- 6 . Temperature range from -40 degree to +70 degree.
- 7.Support echo cancellation.
- 8 . Powder coated in UV stabilized polyester finish.
10. Application: Tunnel, metro, railway, LRT, speedway, marine, ship, offshore, mine, power plant, bridge ect.



## SPECIFICATION

1. PSTN analogue telephone
2. DTMF dialing
3. MTBF:100000hours
4. MTTR: 2 hours
5. Connection: RJ11 screw terminal pair cable
6. Applicable for various types of SPC exchange PABX and dispatching exchange system with feeding voltage of 33-60V.
7. Ambient temperature:-30 ~ +60 degree. Relative humidity:10%~95%  
Atmospheric pressure: 86~106Kpa Circumstance noise:less than60dB(A)
8. Sound level of ringing:over 70dB(A).
9. Standard frequency:low frequency group:697. 770. 852. 941Hz,  
high frequency group:1209. 1336. 1477Hz, frequency deviation:-1.5% ~ +1.5%
10. Call transmission index:(5KM)SLR<12,RLR<-1,STMR>10, output impedance is 600 Ohm.  
maximum distance: 7KM
11. Super strong function is available for dialing 12 groups of numbers stored in the memory  
(maximum length of each number is 16 digits)
12. Connection: RJ11 screw terminal pair cable (or RJ11 Socket of plug upon request)

## CERTIFICATION

Australian communications:AS/CA S004  
Australian Equipment-safety: AS/NZS 60950.1:2015  
RCM: AS/NZS CISPR 32  
EMC:EN55032, EN55024,EN61000-3-2



# INSTALLATION

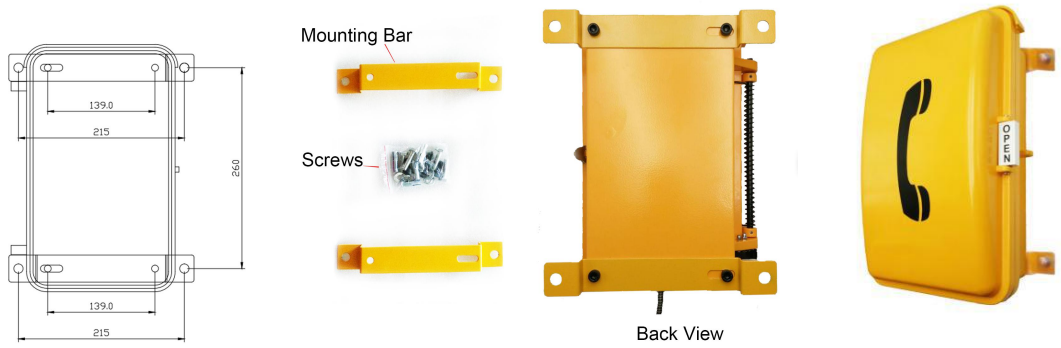
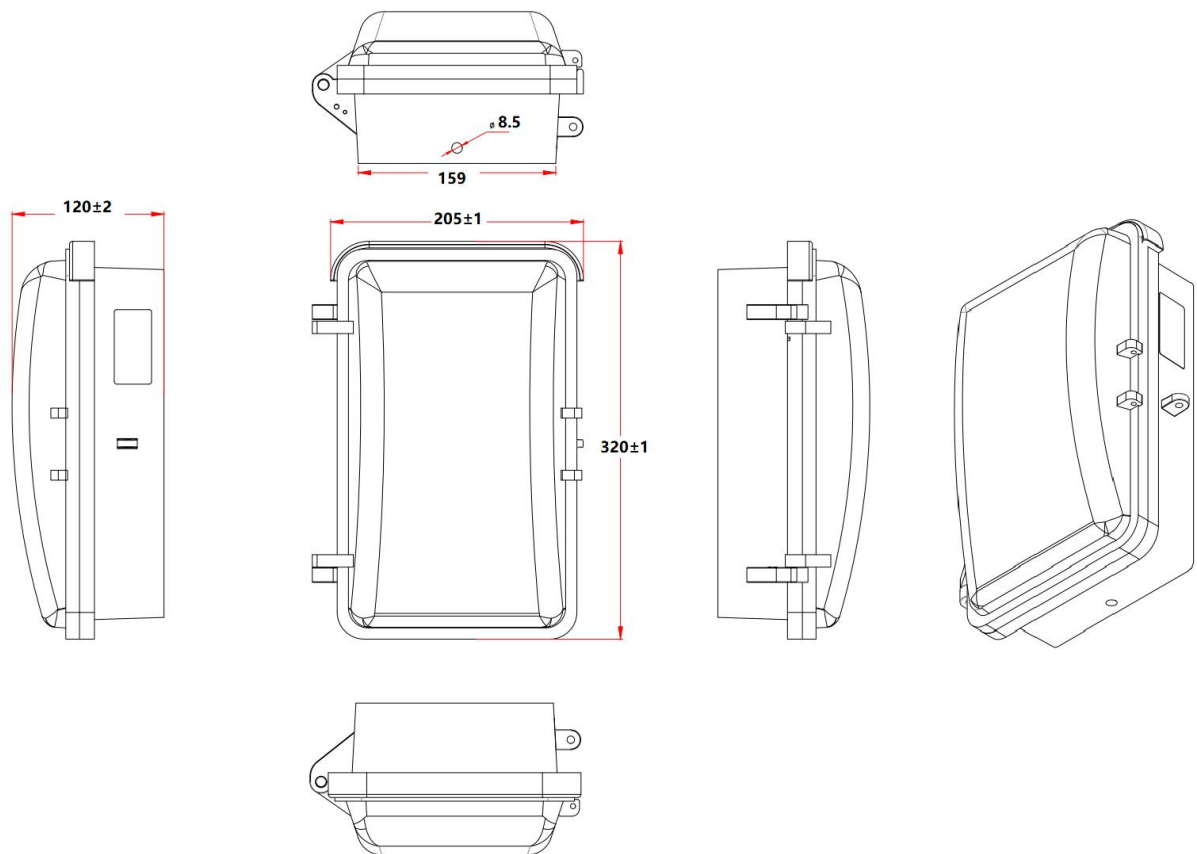

# PACKAGING

Unit size: 320 \* 205 \* 120mm    Unit: N.W: 4.74KG  
 1pcs packing box size: 439 \* 277 \* 191mm    Unit N.W: 5.7KG  
 6pcs in 1 outer Carton box: size: 730 \* 390 \* 340mm    N.W: 35.7KG

